

Teacher's Attitude towards Work Influence Job Satisfaction: An Imminent Stimulus Study for Approaching Pollster's

Surya Sarah Issac¹ and Alice Mani²

Abstract: *The issue of job satisfaction has dependably pulled in incredible consideration among analysts in consisting of enterprise, different fields, enterprise and general society division. This examine is an strive to analyze or to find out the influence of Attitude Towards Work (ATW) on job satisfaction among high school teachers particularly in aided and unaided sectors of Bangalore. To gain the goal, a questionnaire became established and was administered to a sample of 1294 many of the excessive school instructors, teaching in aided and unaided sectors in Bangalore. After assembling the questionnaires the quantitative information was sorted, roundabout as well as broke down primarily supported upon the fundamental topics as well as individual study speculation. The consequences exposed that Attitudes toward work has a positive significant sway on Job Satisfaction ($\beta = 0.199$; $CR = 3.208$, $p < 0.05$). The results offer us with a better expertise of the nature of the hypotheses designates that ATW has a important consequence on job satisfaction as well as performance in a better way of the teachers selected under the sample study. Perhaps, the attitude might not hold an influencing factor on job satisfaction in business sector.*

Keywords: Aided Sector, Attitude towards Work, High School Teachers, Job Satisfaction, Unaided Sector

Introduction

Weiss (2002) characterized job delight as a man or woman's sure quantifiable judgment on his or her running situations. It's far the key detail that prompts achievement and higher execution in an affiliation (Amburgey, 2005). Miskel, McDonald, and Bloom (1995) separated career pleasure into two types' mainly global employment satisfaction, and feature process pleasure. International occupation delight is associated with all levels of employment pride. It clarifies that know-how occupation pleasure itself is quite a whole lot as critical as information man or woman employees appear to be. The second one form of employment pride, feature activity delight, is based on upon a man or woman's rank in the affiliation. In light of the function process pleasure, numerous degrees of career pride are the consequences on the disparity in representatives' running encounters. In instructive area, Caprara, et al. (2006) anticipated that

¹ Research Scholar (Supervised under Dr. Alice Mani), Department of Commerce, Academy of Maritime Education (AMET) University, Kanathur, Chennai.

² Department of Commerce, Christ University, Hosur Road, Bangalore.

Research Guide, Department of Commerce, Academy of Maritime Education (AMET) University, Kanathur, Chennai.

Corresponding author: Surya Sarah Issac can be contacted at: susac48@gmail.com

Any remaining errors or omissions rest solely with the author(s) of this paper

Teacher's Attitude towards Work Influence Job Satisfaction: An Imminent Stimulus Study for employment pride is "definitive component" that has a solid result for instructors' mentalities and even execution.

Hence activity pride is extraordinarily vital fact took place due to self-adequacy. Scientists have confirmed those high-quality teachers' states of thoughts and recognitions are important for possible instructing. Teachers' convictions, observations and dispositions impact their practice and impact the understudies' execution (Eggen & Kauchak, 2002). As indicated by using Ispir (2010), educators' states of thoughts in the direction of displaying calling can influence their school room execution and displaying rehearse, and are related to the burnout stage. As Ushioda (2003) cited, educators being esteemed as an people from the collection like their newcomers, they require the collection development put together, cooperation with special individuals from the gathering, greater odds of shifting in addition of their man or woman gaining knowledge of, appropriate and worthy degree of job and duties. Absolutely, all these vital variables can be accessible in a respectable place of job. Explore on the school adequacy has verified that understudies' results depend very on the nature of guiding principle, that's interrelated to idea and employment pride of the HR.

Throughout the preceding 15 years, teachers' training studies has been produced essentially in taking into consideration educator convictions and the affiliation among educator convictions and instructive practice has as of now been entrenched. Breen (1991) in their studies validated that educators had numerous off base convictions approximately how outside dialects are determined out and people convictions affected educating techniques. Horwitz (1987) predicted that convictions approximately dialect mastering allude to dialect newcomers' assumptions or mind on a collection of troubles diagnosed with 2nd or far off dialect studying. Novices' convictions are those mind, feelings, and musings that they have got approximately themselves, about gaining knowledge of circumstance and target organization (Wesely, 2012).

Assessment of Literature

The goal of the every one of the research have been for the most part to analyze the mind of what is blanketed in knowing a faraway dialects keeping in mind the end purpose to anticipate contentions with recognize to understudies' disappointment, anxiety absence of proposal, and, that can activate quit studying out of doors language (see Schumann and Schumann, 1977; Schumann, 1980). In unique concentrates specifically amid the maximum latest decades, the precept objective was the research of subjective components of dialect studying. Comes approximately proven that individual newcomers make use of one of a kind processes while they're taking in a dialect. Eventually expertise learners convictions approximately dialect mastering would be vital to boom better comprehension in their systems and arranging they research. So it is clean and in mild of what Horwitz (1987) anticipated if convictions about dialect studying exists amongst individuals in one tradition, novices could deliver these convictions with them into the elegance. Furthermore, it is the teachers' duty to put time and push to assist freshmen alternate mind and to make themselves free from the convictions that could piece dialect mastering manner.

In 2001, Peacock researched dialect getting to know convictions evolving. The examination was in fact a longitude thinks approximately in which 146 learner ESL understudies took an interest. They focused on of their three-12 months software on the City University of Hong Kong. The final results proven no noteworthy adjustments, despite the truth that he reviews exceptional in 3 primary regions including getting every other dialect intends to take in

an incredible deal of latest words and sentence shape guidelines, or the individuals who study other dialect are more insightful than the alternative people are.

Kennedy and Kennedy (1996) framed a speculation that "genuine and a hit exchange in educators' practices can simply show up via an adjustment of their convictions". He protected conduct should get from convictions. As he confirmed letting students to illustrate their convictions unequivocally is noteworthy. The cause is that inexperienced persons come to elegance with their convictions which affect on each what they recognize and how they examine. In synopsis teachers' convictions will be inclined to have influences on displaying strategies disposition and techniques. Displaying behavior and learners' advance can be unequivocally influenced with the aid of instructors' convictions. On the quit of the day shaping educators' instructive convictions and tendencies can affect the technique for instructing. The technique for educating may be stimulated by way of educators' proposal. As according to what Dörnyei (2001) said in attitude of educating as a human conduct, it is viable to speak about a trendy version of thought. Therefore, we can keep up that suggestion to educate makes a decision why individuals pick to coach, how relentless there, and what kind of exertion they put into it (Dörnyei, 2001).

Notion is an expression that individuals practice in each day ordinary after they need to discuss the reasons for their behavior. Dialect mastering suggestion investigate has an extended history in the subject of second dialect securing starting from Gardner and Lambert's (1959) which is an established order paintings inside the bilingual setting of Canada. There may be additionally a long-status conviction of inspiration research in instructive mind research. Ryan (1997) highlighted the way that locating an average measure for proposal is a main take a look at, particularly for dialect realizing, that's a multi-faceted wonder. 10 years earlier, attested that inside the area of instructive mind technology he didn't recognize approximately a have a look at that might reveal perception into the connection among teacher and understudy inspiration. several studies were led that highlighted the way that educators' requirement for concept, like understudies a good way to perform better moreover numerous elements that could build their concept (Tziava, 2003).instructors who come across delayed employment stretch will be inclined to have weaker institutions with the understudies prompting a selection in study room administration issues.

Some analysts, as an example, Ryan (1997) have guaranteed that it's miles the instructor's crucial part to inspire their understudies, no matter how unmotivated their newbie's are. Furthermore, as per Landy (1989), the relationship among employment pleasure and career execution has been portrayed because the "Sacred Grail" of mechanical therapists. Ryan (1997) said that educators with strange nation of employment satisfaction anticipate a part of a trainer in addition to a version. Considering educators' career delight could be beneficial to both teachers and beginners, for this reason extra studies must have been finished on educators' discernment towards their employments. Its miles likewise essential to take educators' conviction and mentalities in the direction of displaying calling and its effects for his or her classroom execution into thought.

Nguni, Slegers and Denessen (2006) prevalent that as fulfilled instructors validated a ton of fervor and enthusiasm approximately giving greater energy and time to assist understudies accomplish their scholastic objective, it's miles critical to research all components that have effect on educators' occupation fulfillment. So the desired information might be on hand to beautify and give help the instructive framework to perform composed objective (Perie, 1997). Thoonen (2010) inspected the essentialness of instructors' self-adequacy convictions and their

Teacher's Attitude towards Work Influence Job Satisfaction: An Imminent Stimulus Study for

teaching maintaining in mind the give up goal to recommend motivations to range in understudies' thought. The analyst watched that understudies' concept become decidedly motivated with the aid of associate understudies' fact and beneficial learning strategies. Though, educators' procedure located instructions affect adversely on their understudy motivational behavior. He moreover said that the locating of observe affirmed that educators' self-viability can affect each their teaching and understudies' suggestion to analyze.

The cause for Thoonen (2010) studies becomes to comprehend the convictions and tendencies of educators that have a few conceivable effects on their view of occupation satisfaction in a single little rustic Florida faculty region. A survey that deliberate 20 variables for employment pride and Interviews have been applied to collect required information. The final results exposed that "element perplexity" was shown as a noteworthy wellspring of profession disappointment for educators. These educators frequently got themselves disillusioned at work in view of clashing desires and recognitions among their expert elements as instructors and their social parts inside the group. Likewise talk with statistics tested that an excessive dominant part of educators were upset in light of the truth that they customary distinct instructors to have impact and energy. All in all the exam investigation of the information no longer just affirmed earlier research recommending that numerous elements effect paintings fulfillment, moreover exposed that few issues which had been no longer pronounced in the past investigations of country educating.

Objective of the Study

The study contents two objectives out of that one being major objective and another being minor objective.

1. The major objective of the study is to examine the effect of Attitude towards Work on job satisfaction.
2. To examine the effect of factors (Work Relationship, Motivation, People Environment, Stress) influencing (Statistically significance) the Attitude towards Work.

Hypothesis of the Study

The following hypothesis will be tested for the statistical significance;

- H₁** Attitude towards Works has a positive significant influence on Job Satisfaction
- H₂** Work Relationship has a positive significant effect on Attitude towards Work
- H₃** Motivation has a positive significant effect on Attitude towards Work
- H₄** People Environment has a positive significant effect on Attitude towards Work
- H₅** Stress has a negative significant effect on Attitude towards Work

Primary as well as Secondary Data

The primary data were collected through direct survey method in the course of a self structured questionnaire. The researcher gathered the main source of the primary data from the self structured questionnaires which were distributed at methodically to 1294 high school teachers according to systematic sampling. The researcher collected primary data during the course of the study and performed surveys, personal interviews as well as observations for structuring a self structured questionnaire which was later distributed to the high school teachers in aided and unaided sectors in Bangalore.

The researcher collected the secondary data both from published and unpublished sources. Posted sources like technical and magazines, books, exchange journals and reports,

newspapers and guides of diverse institutions connected with enterprise and industry, schools, and so forth., reports prepared with the aid of studies pupils, universities, and so on., in exceptional fields and in the end public records, facts, historic record and many others. Unpublished sources like letters, biographies, diaries and so forth, have been used all through the direction of the look at.

Ethical Consideration

All of the individuals have been dealt with according with the ethical guidelines of the middle for studies, AMET University and the Institutional assessment Board (IRB). Although there have been no identifiable dangers for collaborating on this study, a couple of issues were stored in mind whilst managing immigrant respondents. First, all of the respondents had been interviewed and talked about their studies as having been working in the high school. Secondly, there was the possibility that respondents felt uncomfortable whilst discussing their studies or speak about non-public records about their running revel in high school. All these issues were included in the course of the studies layout level.

Duration and Context

The survey period changed into, in line with the plan of the take a look at the questionnaire became dispatched out by means of e mail and handouts became immediately distributed to the respondents for about four months, along with pilot have a look at and complete fledges have a look at from the start of December 2015 till the quit of April 2016. The populations of the study become high school instructors were inherent in Bangalore city. This population was centered each on location at excessive faculties as well as via e mail. Finally, teachers at excessive college for the duration of the town Bangalore had been participating inside the examiner. The respondents responded the survey anonymously. The goal populace for the present have a look at was teachers in one-of-a-kind sectors of high faculties, i.e. aided and un-aided sectors. From the target population a sample of 1294 instructors changed into selected for the present examine. The selected sample constituted of 578 instructors from the aided sectors, 718 instructors from the un-aided sectors. Due to the way that no incentives have been provided to the respondents, their preference to take part in the survey was of immaculate intrigue. The quantitative data investigation became blanketed inside the utilization of which changed into later analyzed below AMOS SEM for the very last result software for measurable exam.

Respondent's demographics

The majority of the respondents were female (62.75%), out of which unaided sectors showed the maximum number of respondents (55.33%). The locations were represented by the Bangalore south being 50.62%, followed by Bangalore North being 49.38%. This is because of the reality that the survey changed into performed in Bangalore, India and the e – mail survey was handiest exceeded out to Bengalorians. The demographic records of the respondents are provided inside the given table.

Table 1: Demographics

Variable	Category	Gender		T	R (%)	Type of School		T	R (%)	Work Location		T	R (%)
		Male	Female			Aided	Unaided			North	South		
Gender	Male	482		482	37.25	203	279	482	37.25	204	278	482	37.25
	Female		812	812	62.75	375	437	812	62.75	435	377	812	62.75
Total		482	812	1294	100	578	716	1294	100	100	655	1294	100
Responded (%)		37.25	62.75	100		44.67	55.33	100		49.38	50.62	100	
Type of School	Aided	203	375	578	44.67	578		578	44.67	285	293	578	44.67
	Unaided	279	437	716	55.33		716	716	55.33	354	362	716	55.33
Total		482	812	1294	100	578	716	1294	100	639	655	1294	100
Responded (%)		37.25	62.75	100		44.67	55.33	100		49.38	50.62	100	
Work Location	North	204	435	639	49.38	285	354	639	49.38	639		639	49.38
	South	278	377	655	50.62	293	362	655	50.62		655	655	50.62
Total		482	812	1294	100	578	716	1294	100	639	655	1294	100
Responded (%)		37.25	62.75	100		44.67	55.33	100		49.38	50.62	100	

Fully Fledged Study Data Analysis - Attitudes towards Work (N = 1294)

Having analyzed the pilot study data through CFA necessary precaution was considered -- by dropping the negative loadings (correlation) of items. Both convergent and discriminant validity were performed for the pilot study data. The revised questionnaire was provided to the respondents and accordingly the data were collected from a sample of 1294 respondents. Now, again the CFA analysis (see Figure I) of “Attitude towards Work” measurement model for the complete sample.

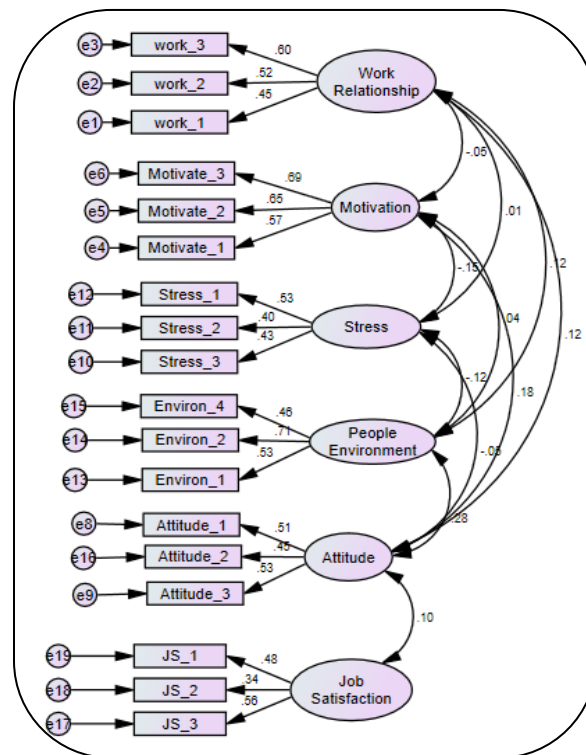

Figure 1: CFA of Measurement Model –Attitude towards Work– Full Fledged Study.

Table 2: Reliability and Item Loadings Constructs of the Measurement Model for Full Fledged Study Data – Attitude towards Work

Latent Variable	Items	Standardized Loadings	Composite Reliability*	Cronbach Alpha	Average Variance Extracted (AVE)
WORK RELATIONSHIP	Work_1	0.450	0.532	0.509	0.277
	Work_2	0.522			
	Work_3	0.598			
MOTIVATION	Motivate_1	0.569	0.669	0.666	0.403
	Motivate_2	0.645			
	Motivate_3	0.686			
PEOPLE ENVIRONMENT	Envirn_1	0.534	0.591	0.505	0.332
	Envirn_2	0.710			
	Envirn_4	0.456			
STRESS	Stress_1	0.429	0.437	0.428	0.208
	Stress_2	0.402			
	Stress_3	0.528			
ATTITUDE TOWARDS WORK	Attitude_1	0.505	0.495	0.497	0.246
	Attitude_2	0.528			
	Attitude_3	0.454			

****Note:** * For calculation the source is

<http://www.thestatisticalmind.com/calculators/comprel/comprel.html>

The composite reliability (Table II) shows the internal consistency of the constructs used which is similar to the cronbach alpha value. The results show the composite reliability of the five constructs are less than 0.70 (Chin, 1998). However, the composite reliability of two constructs namely “*Stress*” and “*Attitude towards Work*” vary between 0.43 and 0.50 and with composite reliability of other constructs namely “*Work Relationship*” (0.532), “*Motivation*” (0.669) and “*People Environment*” (0.591) being less 0.70, nevertheless we proceed for structural equation model due to the fact that goodness fit indices shown in Table III are more or less within the acceptance criteria.

Table 3: Goodness of Fit (GFF) & Incremental Indices of Measurement Model for Attitude towards Work

Fit Indices	Accepted Value	Model Value
Absolute Fit Measures		
χ^2 (Chi-square)		398.113
df (Degrees of Freedom)		124
Chi-square/df (χ^2/df)	< 3	3.211
GFI (Goodness of Fit Index)	> 0.9	0.965
RMSEA (Root Mean Square Error of Approximation)	< 0.10	0.041
Incremental Fit Measures		
AGFI (Adjusted Goodness of Fit Index)	> 0.80	0.952
NFI (Normed Fit Index)	> 0.90	0.820
CFI (Comparative Fit Index)	> 0.90	0.866
IFI (Incremental Fit Index)	> 0.90	0.868

Teacher's Attitude towards Work Influence Job Satisfaction: An Imminent Stimulus Study for

RFI (Relative Fit Index)	> 0.90	0.877
Parsimony Fit Measures		
PCFI (Parsimony Comparative of Fit Index)	> 0.50	0.702
PNFI (Parsimony Normed Fit Index)	> 0.50	0.664

Table 3 depicts the GFF & Incremental Indices of model of Measurement for Attitude towards Work. From the result, it is clearly observed that the majority of the indices are above the accepted value and hence we proceed for SEM model structure.

Result of Hypothesis

The beneath results spots the significance level of the entire five hypothesis selected for the study purpose.

- H₁** Attitude towards Works has a positive significant influence on Job Satisfaction
- H₂** Work Relationship has a positive significant effect on Attitude Towards Work
- H₃** Motivation has a positive significant effect on Attitude Towards Work
- H₄** People Environment has a positive significant effect on Attitude Towards Work
- H₅** Stress has a negative significant effect on Attitude Towards Work

Table 4: Direct Effect of Research Model: Standardized Regression Weights of Job Satisfaction and Attitude towards Work Dimension

Relationships between Exogenous and Endogenous		Standard Estimate	S.E.	C.R.	P-Value	
JS	<---	ATW	0.199	0.078	3.208	0.001*
ATW	<---	Work Relationship	0.105	0.037	2.013	0.044*
ATW	<---	Motivation	0.172	0.031	3.568	0.000*
ATW	<---	People Environment	0.340	0.050	5.881	0.000*
ATW	<---	Stress	- 0.083	0.091	- 0.822	0.411

****Note:**

* Significant at 5 % level

** Significant at 10 % level

The regression consequences are supplied in Table IV. As a result, its miles found that Attitudes towards paintings has an instantaneous high-quality and sizeable have an impact on activity delight ($\beta = 0.199$; $CR = 3.208$, $p < 0.05$), accordingly, H1 is said. Table V affords the précis of take a look at consequences of the look at hypotheses. The regression results are furnished in desk VI. As a consequence, it is determined that work dating has a direct fine and tremendous influence on Attitudes towards paintings ($\beta = 0.105$; $CR = 2.013$, $p < 0.05$), accordingly, H2 is said. Further, Motivation has a direct fantastic and full-size impact on Attitudes toward paintings ($\beta = 0.172$; $CR = 3.568$, $p < 0.05$). Therefore, H3 is asserted. Furthermore, human beings environment has an instantaneous effective and considerable affect on process pleasure ($\beta = 0.340$; $CR = 5.881$, $p < 0.05$). Thus, H4 is said. Finally, it is observed from the above regression result that the p-value of the "Stress" component is 0.441 which is greater that has the significance level of 0.05 ($\beta = - 0.083$; $CR = 1.853$, $p > 0.05$). Thus, H₅ is not asserted. In other words, there is no factual proof to infer that "Stress" will have significant negative impact on Attitudes toward work in the education sector. Table V provides the précis of check consequences of the observe hypotheses.

Table 5: Summary of test results of the study Hypotheses

Hypotheses No	Study Hypotheses	Result
H ₁	Attitude Towards Works has a Positive Significant Influence on Job Satisfaction.	Fully Supported
H ₂	Work Relationship has a Positive Significant Effect on Attitude towards Work	Fully Supported
H ₃	Motivation has a Positive Significant Effect on Attitude towards Work.	Fully Supported
H ₄	People Environment has a Positive Significant Effect on Attitude towards Work.	Fully Supported
H ₅	Stress has a Negative Significant Effect on Attitude towards Work.	Not Supported

Among all the factors, interestingly the “*Stress*” factor does not necessarily have a negative effect/impact on attitudes towards the work. This could be justified by the fact that when we have a good working relationship with colleagues and management, better people or colleagues guiding in the subject matters – where they’re more academic inputs from colleagues, exchange of thoughts and so on, then perhaps the stress factor might offset the negative influence of teacher’s attitude towards work. Again, constant motivation by colleagues and management might also offset the hypothesis that stress would indeed have a pessimistic result or impact lying on one’s attitudes toward work to education sector. Hence, it could be justified that there is no statistical evidence to conclude that stress will always negative influence attitudes toward work given other factors such as work relationship, people environment and motivation are better in any work place.

Findings and Suggestions of the Study

This examine has numerous discoveries, as prominent in this section, Attitudes closer to paintings has an instantaneous effective and giant influence on job pride. For that reason, it is observed that paintings relationship has a right away effective and sizable affect on Attitudes in the direction of work. Similarly, Motivation has a direct effective and considerable have an impact on Attitudes towards work. Furthermore, people environment has a direct advantageous and great have an impact on job satisfaction. sooner or later, it is observed from the above regression end result that the p-price of the “stress” factor is 0.441 that's greater that has the significance degree of 0.05 because of this cause the variable “ stress” is not asserted. In different words, there may be no authentic evidence to infer that “stress” could have sizeable poor impact on Attitudes in the direction of work in the training region.

Amongst all of the factors, apparently the “stress” component does now not always have a negative impact/impact on mindset towards the work. this can to be justified by using the fact that after we've a great work relationship with colleagues and management, better people or colleagues guiding within the difficulty topics – where there greater instructional inputs from colleagues, change of mind and so forth, then perhaps the stress element might offset the poor have an effect on of instructor’s attitude toward work. Once more, consistent motivation by way of colleagues and management may additionally offset the hypothesis that stress would certainly have a poor effect or impact on one’s attitudes towards paintings inside the training quarter. hence, it could be justified that there is no statistical proof to conclude that pressure will continually bad influence attitudes in the direction of work given different factors including work courting, people environment and motivation are better in any work location.

Teacher's Attitude towards Work Influence Job Satisfaction: An Imminent Stimulus Study for

Almost about the maximum noteworthy instructive success, a substantial lot of the educators earned a professional education and similarly ace's unit. Sixty- four percentages of the teachers had eleven to 15 years of provider. Work execution of the educators inside the regions is appraised capable. The greater parts of the instructors are to some degree fulfilled on the accompanying features: school arrangements, supervision, interpersonal family members, open doorways for development and development, running situations, paintings itself, accomplishment, acknowledgment and obligation.

This examine also has few diagnosed pointers, in this section, ranging from information on organizational dedication, to the need for higher work overall performance in trainer's activity delight.

Unaided area respondents are better than respondents of Aided sector; one might conclude the studies examine inspiration as the lecturers belonging to unaided respondents are accepting agreeing strongly that organizational commitment of the academics is influenced via the dedication of the management. In essence, one could finish that instructors belonging to unaided and aided sectors have similar belief bearing on attitude toward paintings. And additionally one could finish that instructors belonging to unaided and aided sectors have similar notion pertaining to activity pleasure.

Primarily based on the findings and hints of the examiner, it's far concluded that the academics of sectors of Bangalore city display a high level of performance related talents, capabilities, productiveness and tasks, exceeding necessities in a few of the regions of labor carried out. The educators of parts of Bangalore metropolis had been mollified with their employment success aspects, as an example, college strategies, supervision, pay, interpersonal relations, open doorways for headway and development, running situations, paintings itself, accomplishment, acknowledgment and duty. This infers an educator's glad with their employment is likewise a gainful one. Except, if the instructors placated with their employment, they will create and preserve up the peculiar state of execution. Displaying mastering method makes greater proficient and possible that would deliver high centered freshmen.

Conclusion and Recommendations for Future Research

Considering the fact that trainer's job delight and overall performance is one of the vital factors in education as like in the business quarter, the prevailing look at aims to provide an explanation for and empirically test the effect or the influence of instructors' mind-set towards work towards job delight. The framework became evaluated the usage of data accumulated from 1294 faculty teachers working in various schools in Bangalore. Numerous implications can be drawn from the findings of the examiner. first of all, from the consequences acquired through the take a look at of hypotheses suggests that mindset closer to work have a giant impact on process delight and activity overall performance in a better way of the teachers decided on under the pattern examine. Perhaps, the mindset may not preserve an influencing aspect on task pride in business area (Aries Susanty, Rizqi Miradipta, 2013).

From a theoretical angle, the researcher's normal findings support the idea that attitude closer to paintings and activity satisfaction are moderately or less moderately correlated. These findings guide the theoretical purpose that attitude closer to paintings is a huge predictor of job satisfaction among teachers in the educational establishments.

There are a huge variety of chances to enhance this have a look at. For example, facilitate concentrates on occupation fulfillment estimations can concentrate on issues on how distinct socio demographic elements have an effect on employment fulfillment measurement. Any other

open door may additionally likewise watch out whether the obvious profession success degrees range by international locations in change city areas in India.

A similarly road to increase this research is to observe special sectors (e.g. international area, government area) to beautify the knowledge of teacher's belief of expectation domestically or across the world.

In the close to future, the researcher is making plans to run a complete variety of experiments to decide the residences of an amazing job delight shape. A full variety of problems may be studied inclusive of the satisfactory predictor for process delight structure. The researcher may even revisit the issue of specialized cluster inputs.

Reference

- Amburgey, W. O. (2005). An analysis of the relationship between job satisfaction, organizational culture, and perceived leadership characteristics. Doctoral dissertation, University of Central Florida (UMI No.3188100).
- Breen, M.P. (1991). Understanding the language teacher. In: Phillipson R, Kellerman ES, Selinker MS, Sharwood M, and Swain M (eds) Foreign/Second Language Pedagogy Research. Clevedon, UK: Multilingual Matters, 213-33.
- Caprara, G. V., Barbaranelli, C., Steca, P., & Malone, P. S. (2006). Teachers' self-efficacy beliefs as determinants of job satisfaction and students' academic achievement: A study at the school level. *Journal of School Psychology*, 44, 473-490. <http://dx.doi.org/10.1016/j.jsp.2006.09.001>
- Dörnyei, Z. (2001). Teaching and researching motivation. Essex, England: Pearson Education Limited. Edward Arnold, London.
- Eggen, P., & Kauchak, D. (2002). Strategies for teachers: Teaching content and thinking skills (4th ed.). Needham Heights.
- Gardner, R., & Lambert, W. (1959). Motivational variables in second language acquisition. *Canadian Journal of Psychology*, 13, 266-272. <http://dx.doi.org/10.1037/h0083787>
- Horwitz, E. K. (1987). Surveying student beliefs about language teaming. In A. L.Wenden & J. Robin (Eds.), *Learner strategies in language learning* (pp. 119-132).London: Prentice Hall.
- Horwitz, E. K. (1987). Surveying student beliefs about language teaming. In A. L.Wenden & J. Robin (Eds.), *Learner strategies in language learning* (pp. 119-132).London: Prentice Hall.
- Ispir, O. A. (2010). Teachers' burnout levels and their attitudes towards teaching profession. EABR & ETLIC Conference Proceedings (pp. 229-233). Dublin, Ireland.
- Kennedy, C. & Kennedy, J. (1996) Teacher Attitudes and Change Implementation, *System*, 24(3), pp. 351-360.
- Landy, F. J. (1989). Psychology of work behavior. Pacific Grove. CA: Brooks/Cole.
- Miskel, C., McDonald, D., & Bloom, S. (1983). Structural and expectancy linkages within schools and organizational effectiveness. *Educational Administration Quarterly*, 19, 49-82. <http://dx.doi.org/10.1177/0013161X83019001004>
- Nguni, S., Slegers, P., & Denessen, E. (2006). Transformational and transactional leadership effects on teachers' job satisfaction, organizational commitment, and organizational citizenship behavior in primary schools: The Tanzanian case. *School Effectiveness and School Improvement*, 17, 145-177. <http://dx.doi.org/10.1080/09243450600565746>

Teacher's Attitude towards Work Influence Job Satisfaction: An Imminent Stimulus Study for

- Perie, M. & Baker, D. P. (1997). Job satisfaction among America's teachers: Effects of workplace conditions, background characteristics, and teacher compensation. Statistical analysis report. (ERIC Document Reproduction Service No. ED 412 181).
- Ryan, R. M., & Deci, E. L. (2000). Self-determination theory and the facilitation of intrinsic motivation, social development, and well-being. *American Psychologist*, 55, 68–78. <http://dx.doi.org/10.1037/0003-066X.55.1.68>
- Schumann, F. M. (1980). Diary of a language learner: A further analysis. In R. C. Scarcella & S. D. Krashen (Eds.), *Research in second language acquisition: Selected papers of the Los Angeles second language acquisition research forum* (pp. 51-57). Rowley, MA: Newbury House.
- Schumann, F. M., & Schumann, J. H. (1977). Diary of a language learner: An introspective study of second language learning. In H. D. Brown, C. A. Yorio, & R. H. Crymes (Eds.), *On TESOL '77 - Teaching and learning English as a second language: Trends in research and practice* (pp. 241-249). Washington, DC.
- Thoonen, E. E. J., Slegers, P. J.C., Peetsma, T. T. D., & Oort, F. J. (2010). Can teachers motivate students to learn? *Educational Studies*, 73(3), 345-360.
- Tziava, K. (2003). Factors that motivate and demotivate Greek EFL teachers. Doctoral dissertation, The University of Edinburgh, Moray House School of Education. Retrieved from <http://hdl.handle.net/1842/495>
- Ushioda, E. (2003). Motivation as a socially mediated process. In D. Little, J. Ridley & E. Ushioda (Eds.), *Learner autonomy in the foreign language classroom: Teacher, learner, curriculum and assessment* (pp. 90- 102). Dublin: Authentic.
- Weiss, H. M. (2002). Deconstructing job satisfaction setting evaluations, beliefs, and affective experiences. *Human Resource Management Review*, 12(2), 173-194. [http://dx.doi.org/10.1016/S1053-4822\(02\)00045-1](http://dx.doi.org/10.1016/S1053-4822(02)00045-1)
- Wesely, M. (2012). Learner attitudes, perceptions, and beliefs in language learning. *Foreign Language Annals*, 45 (1), 98–117. <http://dx.doi.org/10.1111/j.1944-9720.2012.01181.x>